



ITIS B.V.
 Daniëlsweg 6
 NL-4451 HP Heinkenszand
 T + 31 113 568515
 info@itis-nl.com
 www.itis-nl.com

ITIS Certificate
 22043-C003 revision 2
 Annex 1: F47X drawing
 Annex 2: F47W drawing



Industrie Service

API607 AND ISO 10497 FIRE TEST QUALIFICATION CERTIFICATE

This certificate is to certify that the valve below has been tested in accordance with and meets all limits stated in API Standard 607, sixth edition September 2010; Fire test for quarter turn valves and valves with non metallic seats, and ISO 10497 third edition 2010-02-15 Testing of valves - Fire- type testing requirements.

Test valve details

Manufacturer : Habonim Industrial Valves & Actuators
 Address : Kfar Hanassi 12305
 Nominal size : DN100 4 inch
 Pressure rating : 300 lbs
 Type : 40-AF47X-4466PG/05 NPT (Split body floating ball valve)
 Weight : 31 kg (approximately)
 Bore : full bore
 Drawing number : 40-AF47X-FIRE-TEST rev.N 04-04-2012
 Body material : A216 WCB
 Body seal material : Graphite
 Ball material : A351 CF8M
 Seat material : CF PTFE (NRG)
 Stem material : A479 316L
 Stem seal material : CF PTFE (NRG) (1x), stem trust seal: PEEK® (2x)
 Serial number : 22043003
 Markings on valve : Materials, size and class on valve tag plate, serial no. On valve body
 Gearbox fitted : No

Scope of other sizes, pressures and materials qualified by this test.

For material qualification see paragraph 7.2 in report mentioned below.

Valve types with same basic design as tested valve. According Habonim information	7.3 Nominal Size	7.4 Pressure rating
F47X becomes F47W	4inch, 5, 6 and 8inch DN100, DN125, DN150, and DN200	Class 300, 400 and 600 PN40, PN63 and PN100

This certificate is only valid in conjunction with the full ITIS BV test report number 22043-R003

Signature operator (ITIS)
 F. Huiszoon

 F. Huiszoon
 11-07-2013

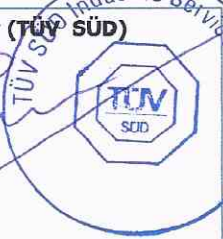
Agreed authority (TUV SUD)
 P. Deleu

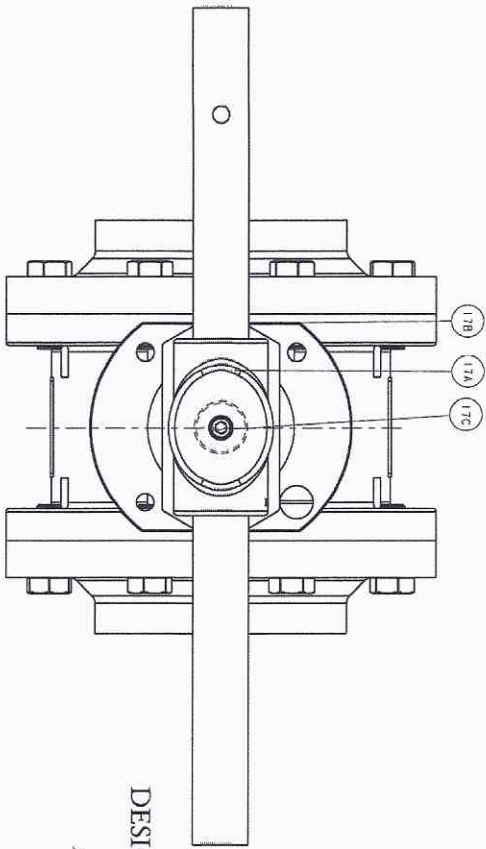
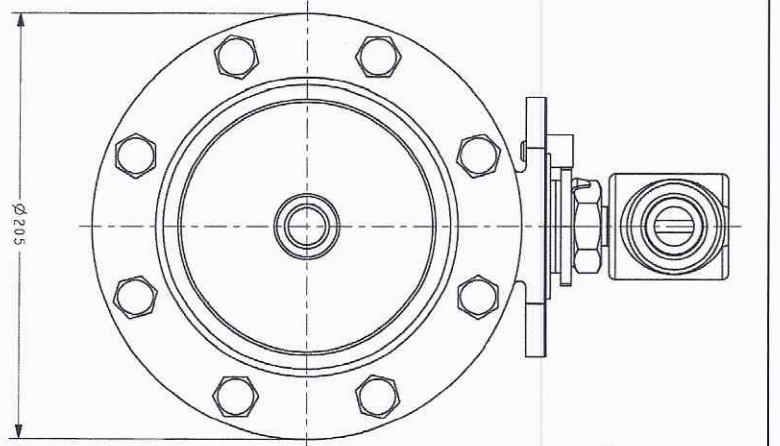
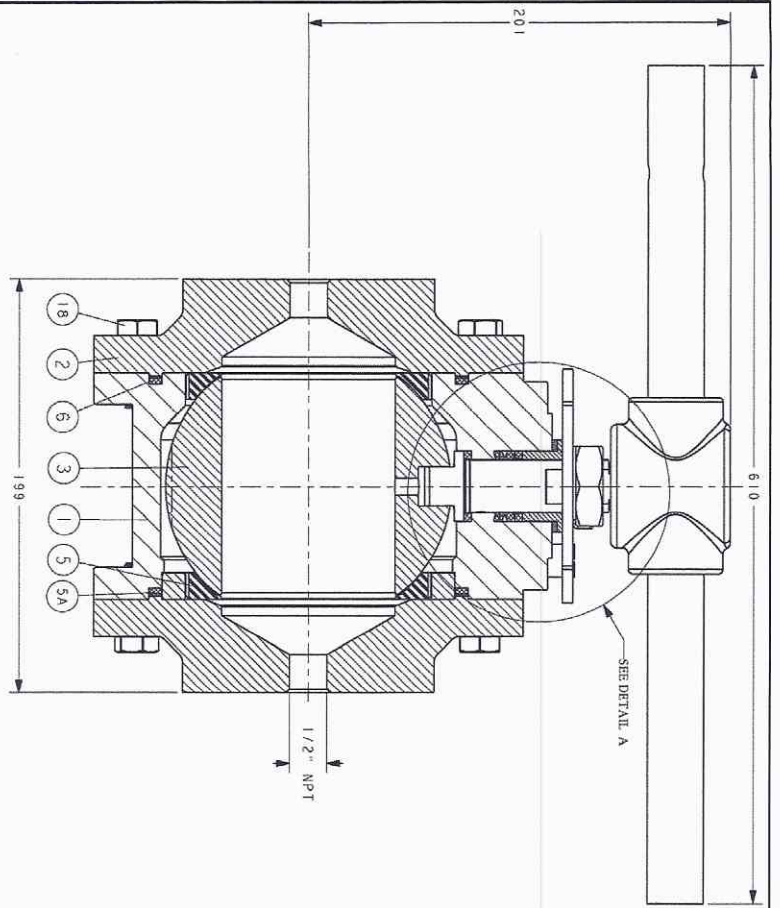
 11-07-2013

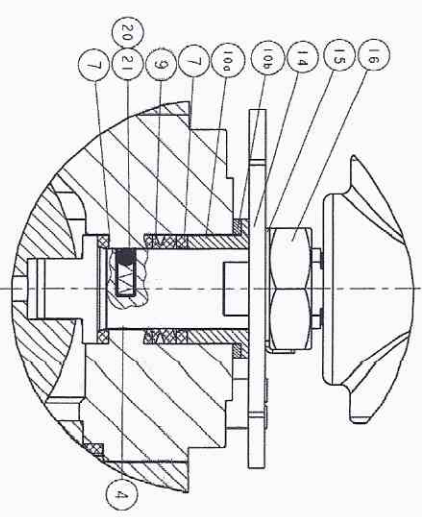
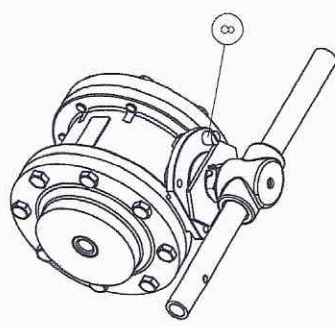

DESIGN STANDARD: ASME B16.34
 PRESSURE CLASS: #300
 APPROX. WEIGHT: 31 Kg



DETAIL A
 SCALE 1:00

Item	Description	Material Specifications	Qty.
1	Body	A216 WCB	1
2	Ends	A216 WCB	2
3	Ball	A351 CF8M	1
4	Stem	A179 316L	1
5	Seat	CF PTFE (NRCG)	2
6	Body seal	Graphite	2
7	Stem thrust seal	PEEK®	2
8	Stop pin	A582 303	1
9	Stem packing	CF PTFE (NRCG)	1
10A	Follow-up	A179 316L	1
10B	Sliding Washer	Stripped Bronze	1
14	Stop Plate	A240 430	1
15	Tab Lock Washer	A194 6	1
16	Stem Nut	A194 8M, 8MA	1
17A	Wrench Head	A351 CF8M	1
17B	Wrench Handle	A240 316L	1
17C	Wrench Bolt	A193 B8M, B8MA, B8M2, B8M3	1
18	Body bolts	A193 B8M, B8MA, B8M2, B8M3	16
20	Anti static spring	A313 302	2
21	Anti static plunger	A479 304	2
23	Tag/Port (shown)	A167 304	1

DESIGNER	CHKD	APPD	DATE	REV
100 N	29-06-11	29-06-11	4.0-AF-47X-F-REC-TEST	0.0

HABONIM INDUSTRIAL VALVE LTD.
 4" AF47XRB VALVE FOR FIRE TEST

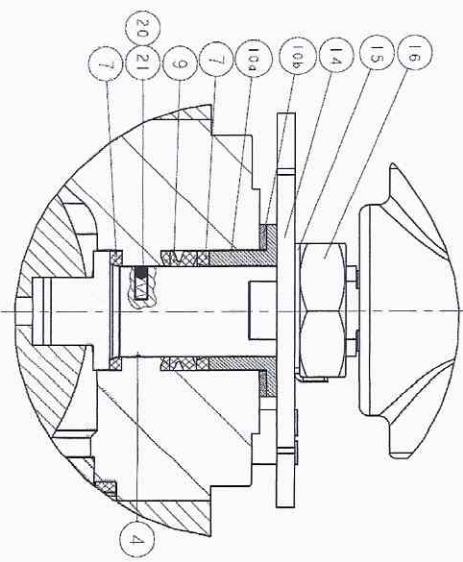
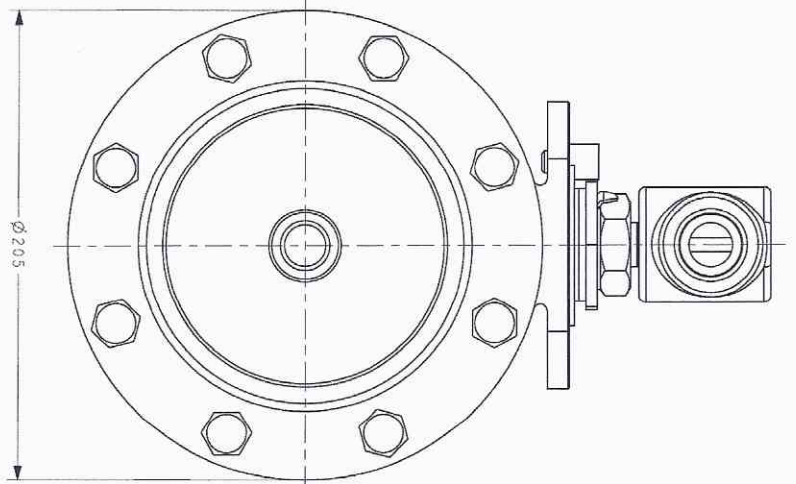
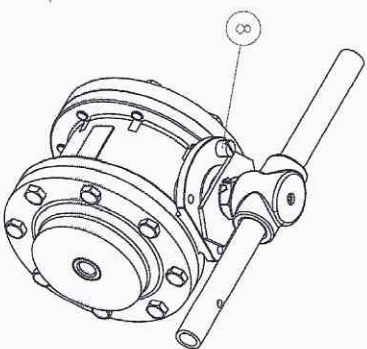
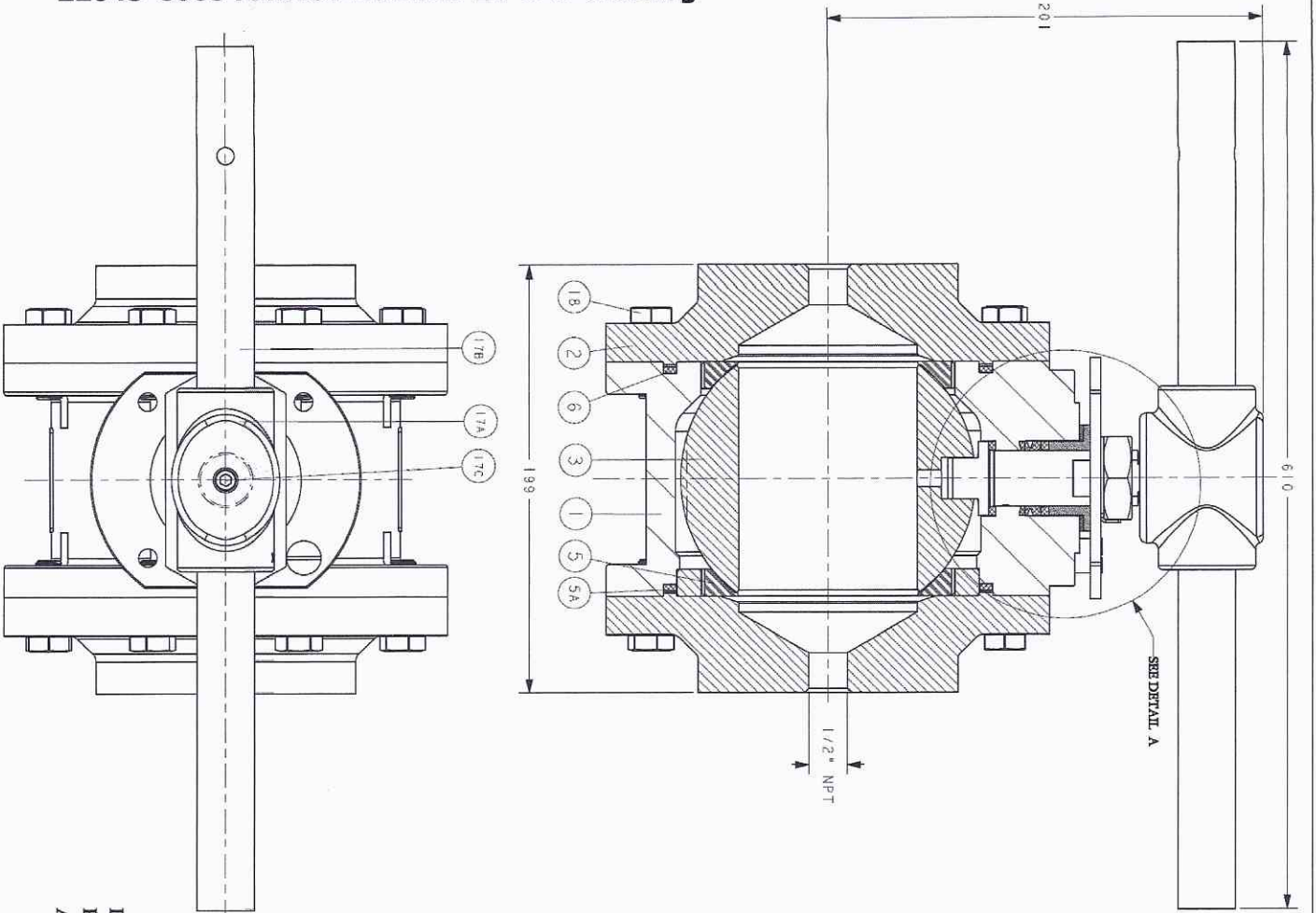

DETAIL A
SCALE 1:1000

Item	Description	Material Specifications	Qty.
1	Body	A216 WCB	1
2	Ends	A216 WCB	2
3	Ball	A351 CF8M	1
4	Stem	A479 316L	1
5	Seat	CF PTFE (NRG)	2
6	Body seal	Graphite	2
7	Stem thrust seal	PEEK®	2
8	Stop pin	A582 303	1
9	Stem packing	CF PTFE (NRG)	1
10A	Follower	A479 316L	1
10B	Sliding Washer	TC316	1
14	Stop Plate	A240 430	1
15	Tab Look Washer	A194 6	1
16	Stem Nut	A194 8M, 8M/A	1
17A	Wrench Head	A351 CF8M	1
17B	Wrench Handle	A240 316L	1
17C	Wrench Bolt	A193 B8M, B8M/A, B8M/2, B8M/3	1
18	Body bolts	A193 B8M, B8M/A, B8M/2, B8M/3	16
20	Anti static spring	A313 302	2
21	Anti static plunger	A479 304	2
23	Tag(not shown)	A167 304	1

DESIGN STANDARD: ASME B16.34
PRESSURE CLASS: #300
APPROX. WEIGHT: 31 Kg

HABONIM Industrial Valves & Actuators		
Drawing No. 40-F47W-FIRE-TEST	General Information	
Item No. 08R0051840-FIRE-TEST	Made From 08R0051840	
LINEAR TOLERANCES: ± 0.25	ANGULAR TOLERANCES: ± 0.5°	
SURFACE FINISH: N8	Unit: (MM)	
Part No. 40-F47W-FIRE-TEST	Date: 20.06.11	
Product Name: 4" F47W VALVE FOR FIRE TEST		
CHANGE	WAS	HA
Rev.	Approved By	Rev.
HA00	MG	MG