



Installation, Operating & Maintenance 3-Piece High Pressure Ball Valves

Series Included:

28X, F28W

Sizes Included:

1/4" - 8" (DN6-DN200)

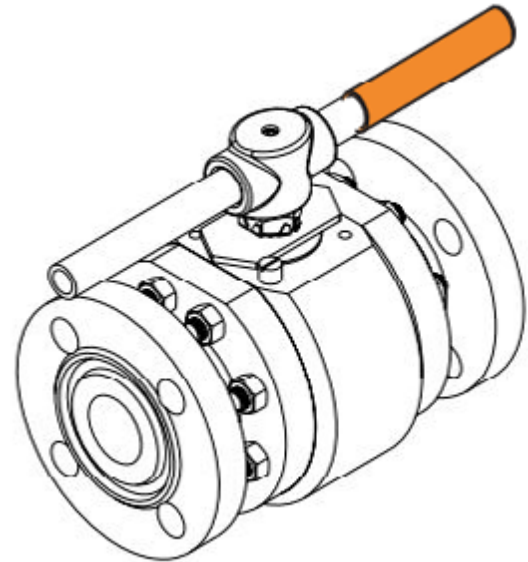

1. GENERAL

This Installation, Operating & Maintenance manual present the instructions required for safe use of Habonim 3-piece high pressure ball valves type 28 series. The manual relates to reduced bore and full bore. Before using any of these series valves, read the entire IOM carefully and make sure you understand everything. Where in doubt, please consult with Habonim Engineering team.

WARNINGS & SAFETY INSTRUCTIONS

Habonim cannot anticipate all of the situations a user may encounter while installing and using Habonim valves. The user MUST know and follow all applicable industry specifications on the safe installation and use of these valves. Misapplication of the product may result in injuries or property damage. Refer to Habonim product catalogues, product brochures and installation, operating and maintenance manuals for additional product safety information or contact Habonim.

1. Keep hands and objects away from the valve ports at all times. Actuated valves could be accidentally operated, resulting in serious injury or valve damage.
2. Before removing a valve from the line, always make sure the line has been depressurized and drained. Cycle the valve a few times to relieve any pressure that could be trapped in the body cavity.
3. Utmost caution must be taken when handling a valve that has toxic, corrosive, flammable or a contaminant nature media flowing through its pipeline. The following safety precautions are recommended when dismantling valves with hazardous media:
 - Wear eye shield, protective headgear, clothing, gloves and footwear.
 - Have available running water.
 - Have a suitable fire extinguisher when media is flammable.
4. Do not try to operate a valve that exhibits any sign of leakage. Isolate the valve and either repair or replace it.
5. Do not use or substitute non Habonim components or parts in Habonim valves and assemblies.



2. SIL

Under normal operating conditions the Habonim valve should be inspected for proper functioning and signs of deterioration every 50,000 cycles or 6 months (whichever comes first). Under severe operating conditions inspection should be more frequently; detected defects should be repaired promptly.

- Application temperature less than -60 deg C
- Application temperature higher than +260 deg C
- Application pressure higher than 414 bar (class 2500)
- Flow velocity higher than 5 m/sec for liquids, and 200 m/sec for gaseous
- Acidic media PH < 5 or alkaline media PH > 9
- Differential pressure above 255bar

Habonim recommend a proof test interval of 12 months; in case of Fail to Open ESD system a partial stroke is acceptable to confirm that the installation is functioning properly.

For ESD systems with a Fail-To-Close demand, it is necessary to plan a system shut-down; de-energize the system and inspect the valve turning to its fully closed position.

It is essential to log-in the following parameters on site QA records as a proof for preserving SIL capabilities: date, hour, name and signature of the responsible engineer, air pressure on site, time to close the valve, time to open the valve.

Habonim recommend valve full maintenance operation every 500,000 cycles or 4 years, whichever comes first (refer to **para. 7** in this IOM for maintenance instructions). The combined corrosion and erosion allowance for the valve body wall thickness is 1 mm. When this allowance has been eroded or corroded, mechanically removed or otherwise, the valve should no longer be used. Inspect the valve wall thickness every time the valve is maintained. Refer to Habonim Corrosion Data Chart T-614 to determine the corrosion rate for your application.

The estimated mean time to repair (MTTR) a valve, i.e. time net (line draining or cooling down time excluded from the valve MTTR) of replacing old valve with a new one is 60 minutes. Maintenance team must read and understand the Habonim product IOM before starting the operation. In case of a doubt please consult the Habonim engineering team.

When a valve has been repaired or any maintenance is performed, check the valve for proper function (proof testing). Any failures affecting functional safety should be reported to the Habonim factory. Client should consult the Habonim factory in order to obtain the product assessment, FMEDA report, and other associated statistical data to satisfy SIL level.

3. LIMITATIONS

The correct selection of materials of construction, seats and seals, internal valve components and pressure/temperature ratings determines the safe use of the valves and the particular performance requirements for the application. This information can be found on the nameplate welded to the valve body.

As the extent of applications that these valves can be used in, is large, it is not possible to cover all installation and maintenance instructions for service of the valves. It is the user's responsibility to use the valves as recommended and in accordance with the pressure and temperature limits as stated in this manual. Where in doubt, please consult with Habonim.

Any unstable fluid or gas should be identified by its manufacturer and must not be used with Habonim valves.

CAUTION:

The valves should be used in a well designed, adequately protected system to ensure **that external and internal pressure and temperature limits do not exceed the valve limits.**

The valve body rating can be higher than the seat rating.

Valve surface temperature may become extremely hot or cold due to ambient or operating conditions. Prevent any type of direct contact with the valve that may cause harm or injury. Avoid direct contact with the valve by wearing protective gloves.

The valves should be used in a well designed, adequately supported piping system such that it will not be subjected to undue forces, stresses or shock loads during service.

The valves are not designed to operate during or after earthquakes or under fatigue conditions. It is the responsibility of the owner to determine if fatigue conditions exist.

Do not allow dust layers to build up on the equipment.

The process fluid temperature shall not exceed the ignition temperature of the dust.

4. STORAGE

Prior to storage, inspect the valve for shipping damage. Keep all protective packaging, flange covers and end caps attached to the valves during storage. It is recommended to keep the valves in a clean and dry environment until ready for use.

5. LONG TERM STORAGE

- 5.1. It is advisable to store the valves in waterproof conditions. Ball valves should be protected to safeguard against humidity, moisture, dust, dirt, sand, mud, salt spray, and sea water.
- 5.2. Manual ball valves must remain in the open position during the period of storage.
- 5.3. Actuated valves (fail to close position) remain in closed position during this time.
- 5.4. Valves may be stored as shipped, provided the above storage location and equipment orientation instructions are followed
- 5.5. In order to prevent damage, protective covers on valve ends should not be removed until immediately prior to installation.
- 5.6. Visual inspection should be performed on a semi-annual basis and results recorded.
- 5.7. If the actuated valve (fail to close position) is planned for long storage after dispatch it will be necessary to operate once in 6 months for fully open/close position.
- 5.8. Ball valves should be operated for at least two complete cycles before installing or returning to storage.

6. OPERATING INSTRUCTIONS

Habonim Valves provide tight shut off when used under normal conditions and in accordance with Habonim's published pressure/temperature chart. If these valves are used in a partially open (throttled) position, seat life may be reduced. Consult with Habonim for the proper seat material selection.

Valve operation works by operating the valve handle 90° turn counter-clockwise to open, and 90° turn clockwise to close. On manually operated valves the valve is open when the handle or stem flats are parallel with the pipeline and closed when the handle or stem flats are perpendicular to the pipeline.

All standard valves are bidirectional and as such, can be installed for flow in either direction. Valves which are unidirectional will have a flow direction arrow welded to the body and separate assembly instructions.

A silicone-based lubricant is applied to assist valve break in. The lubricant, if unacceptable, may be removed by a solvent wash.

If a shut-off valve is installed for end of line service, it must be ensured that it is closed with a blind end connection and the valve is secured against being opened unintentionally.

WARNING: Never look into the valve bore while the valve is in a flowline. Pressure and fluids could escape from the valve causing injury. To prevent leakage, malfunctions resulting from internal wear or seal degradation, the user must establish a preventive maintenance and inspection program. This program must include:

- a. Inspection of parts to detect loss of wall thickness which may result in decreased pressure capacity (see **para. 2** for acceptable reduction of wall thickness).
- b. Routine replacement of seals and inspection for proper operation (See **para. 8** for maintenance instructions).

Valve operating torques as published in the Habonim literature are the normal expected maximum break-away torques. These torques have been confirmed by laboratory testing of each valve under controlled conditions. Highly viscous or abrasive media, frequency of operation and temperature fluctuations could cause an increase in valve torque.

7. INSTALLATION

The installation procedure for ball valves is critical to ensuring both long life and satisfying performance. Valves stored on site awaiting installation should be kept in their original packing, in dry conditions, where damage cannot occur (see **para. 4**). Before carrying out the installation, it is important to follow the basic procedures described below:

7.1 General

- 7.1.1. Carefully unpack the valve and check valve nameplate for identification of materials (see **Figure 2**).
- 7.1.2. Remove any special packing materials, which were used for packing.
- 7.1.3. Check the valve for any flow direction indication marks. Appropriate care must be taken, to install the valve for proper flow orientation.
- 7.1.4. Inspect the valve interior through the end ports to determine it is clean and free from foreign matter according to ASME G93-03E1.
- 7.1.5. Cycle the valve and inspect any functionally significant features.
- 7.1.6. Read all the literature and note any special warning tags or plates attached to the valve.
- 7.1.7. Before installation check to insure the ball is in the fully open position in order to prevent possible damage to the ball and seats. The valve performance depends on its original conditions. At any stage do not leave the valve in the partially open position.

7.2 Threaded End Valves

- 7.2.1. Valves with threaded ends should be treated as a single unit and should not be dismantled when installing to pipeline.
- 7.2.2. Before installing the valves, make sure that the threads on the mating pipe are free from excessive grit, dirt or burrs.
- 7.2.3. When tightening the valve, apply a pipe wrench or spanner to the end connector closest to the pipe being worked, using standard piping practices.
- 7.2.4. Use appropriate joining sealants material in correct quantities.

- 7.2.5. If “back-welding” is required on threaded end valves, refer to the instructions for Weld End valves or to the “Habonim Welding Instructions” bulletin.

7.3 Weld End Valves in-line

- 7.3.1. Welding of valves shall be performed by a qualified person according to the ASME Boiler Construction Code Section IX. For valves to be welded within the EEA, refer to the requirements of ESR 3.1.2 of the Pressure Equipment Directive 97/23/EC.
- 7.3.2. Valves with Delrin® seats must be disassembled before welding in line. For more information on recommended welding procedures or seat materials, please consult with Habonim.
- 7.3.3. Valves that will be welded directly to the line must be in the fully open position to protect the ball and seats from excessive temperatures during the welding procedures.
- 7.3.4. It is recommended to remove the valve wrench during the welding procedure. Protect or remove actuators from weld splatter or arc strikes. Valves in the “Fail Close” position should be cycled to the open position.
- 7.3.5. Use a temperature stick and a wet cloth wrapped around the center section to prevent overheating. DO NOT heat the center section over 150°C (300°F).
- 7.3.6. Align valve to pipe line, ensuring proper fit to minimize pipe load. Tack weld only.
- 7.3.7. Complete welding in small segments. Allow enough time for cooling between each segment.
- 7.3.8. After completing the welds, wait for the valve to cool below 90°C (200°F). Tighten the body bolts to torque figures and tightening patterns according to **Figure 1**.
- 7.3.9. Replace the wrench or actuator. It is recommended not to rotate the valve to the closed position before flushing the line.

7.4 Weld End Valves not in-line

- 7.4.1. Welding of valves shall be performed by a qualified person according to the ASME Boiler Construction Code Section IX. For valves to be welded within the EEA, refer to the requirements of ESR 3.1.2 of the Pressure Equipment Directive 97/23/EC.
- 7.4.2. Valves that will be disassembled before welding carry a packet with replacement body seals. Follow steps 2 to 9 of the DISASSEMBLY section but do not discard of the seat rings.
- 7.4.3. Prior to welding the ends to the pipe, make sure their flats are aligned to the body flats (see NOTE on **page 6**).
- 7.4.4. Do not scratch or cut the seats and sealing surfaces of the valves as this will cause valve leakage.
- 7.4.5. Assemble the valve without the ball and seats and follow steps 1 to 7 for Weld End Valves.
- 7.4.6. After the valve cools down, follow again **steps 2 to 9** of the DISASSEMBLY section and **section 7 to 13** of the ASSEMBLY section.

7.5 Flanged Valves

- 7.5.1. Before installing the valves, make sure the flanges and the pipe are free from grit, dirt or burrs.
- 7.5.2. The flanges must be aligned and parallel with the correct distance to allow the valve face-to-face dimension and gaskets to fit between.
- 7.5.3. Insert the valve between the flanges. If tilting or levering of the flanges is required, avoid harming the sealing surfaces of the flanges.

- 7.5.4. Align the valve and the pipe counter flanges and insert at least 2 bolts at the lowest side of the flange to support the gaskets.
- 7.5.5. Slide the gaskets between the flanges. Insert the remaining bolts and thread the nuts hand tight.
- 7.5.6. Before tightening the bolts, make sure the gaskets are aligned with the raised face of the flanges.
- 7.5.7. Tighten the flange bolts, with a torque values determined by the gasket manufacturer, other variables like gasket type and material, bolt, flange and lubricant affect the tightening torque values.

IMPORTANT - the tightening torque selected must be high enough to ensure adequate strain (stretch) in the bolt, but not so high as to cause the material to be taken beyond yield into the plastic response region. If the initial bolt stress is too low the total amount of strain (stretch in the bolt) is low and under these circumstances any subsequent reduction in thickness of the gasket due to creep will quickly result in loss of bolt strain and subsequent leakage.

- 7.5.8. It is recommended to use ring spanners to tighten and support the bolts and nuts.
- 7.5.9. Note: bolts tightening must be uniform in order to create a parallel movement of the two flanges and uniform deformation of the gasket in between them.
- 7.5.10. Before flushing the line, be sure the valves are in the fully open position. Fail-to-close actuated valves should be operated to the open position for flushing.
- 7.5.11. Before pressure testing the valves, bring the valves to the half-open position to ensure pressure reaches the stem seals and to avoid unnecessary loading of the seats. Fail-to-close actuated valves should be brought to the half-open position.

8. MAINTENANCE

HABONIM valves have a long and trouble free life, and maintenance is seldom required. When maintenance is necessary, valves can be refurbished on site.

To extend valve performance and reduce possible plant problems, the following procedures should be followed:

- 8.1. If leakage at the stem is noted, check the torque of gland nut according to **table 1**. If leakage continues, tighten the gland nut about a 1/6-turn as a routine maintenance procedure. This will compensate for any wear or settling of the gland packing.
- 8.2. **Caution:** Excessive tightening of the stem nut can result in accelerated seal wear and high valve operating torque.
- 8.3. If the valve is removed from the line and disassembled, replacement of all seats and seals is recommended using the appropriate Habonim Repair kit. Examine all metallic sealing surfaces such as ball, stem, and the surfaces on the end connectors that contact the seats for wear, corrosion or damage.
- 8.4. Only Habonim's authorized spare parts should be used. Repair kits from Habonim consist of the following:
 - 2 x Hybrid seats with inserts (5, 5A)
 - 2 x seat seals (5B)
 - 2 x body seals (6)
 - 2 x additional seat seals (only for NBR or Viton® O-ring sealed valves) (5C)
 - 1 x stem packing (9)
 - 1 x stem thrust seal (7)
 - 1 x antiabrasion ring (7a)
 - 1 x slide Bearing (only for fire safe applications) (10A)

- 8.5. In addition to repair kits, other spare parts available from Habonim are: valve balls, stems, glands, bolts, screws and nuts. Should additional parts be required, it is recommended that the complete valve be replaced.
- 8.6. When ordering repair kits, please provide the valve size and full figure number code and series.

9. DISASSEMBLY

The following instructions are for in-line disassembly of valves sizes ¼" to 1 ¼" (or 1" full bore).

- 9.1. Cycle the valve with the line pressure fully relieved before attempting to remove the valve from the pipeline, to insure pressure has also been discharged from the valve cavity.
- 9.2. Bring the valve handle to the open position. Warning: trying to remove the valve body from the line in the closed position will damage the ball.
- 9.3. With the valve in the open position, loosen all body bolts.
- 9.4. Remove all body bolts.
- 9.5. Swing out the body from between the end connectors.
- 9.6. Remove and discard the hybrid seats, the seat and body seals. Be careful not to damage the sealing surfaces.
- 9.7. Support the ball to prevent it from falling out of body and turn handle to the closed position for its removal. Set the ball aside in clean secure area for reuse.
- 9.8. Remove the handle nut, serrated washer, handle, locking clip, stem nut, disk springs, follower and the slide bearing. Place all components removed, in clean secure area.
- 9.9. Push the stem down into the body and remove it. Discard the stem thrust seal bearing and packing, take care not to scratch or nick the stem bore area of the body. Clean the stem and stem bore area. The following instructions are for in-line disassembly of valves sizes 1.5" to 8".

10. Small valves assembly

The following instructions are for in-line assembly of valves sizes ¼" to 1 ¼" small valves.

- 10.1. Lubricate the new stem thrust seal (7), bearing (10A) and packing (9), with appropriate lubricant (Molykote 33 - thin smear). Place the stem thrust seal on the stem (4).
- 10.2. Insert the stem horizontally into the center body (1) with the threaded side first and carefully guide it up through the stem bore.
- 10.3. Holding the stem up insert the new packing (9) over the stem and into the stem bore. Place the stem antiabrasion ring (7a), slide bearing (only in fire safe valve), follower and two disk springs onto the stem (10A, 10, 11). The first spring convex side down and the second spring convex side up.
- 10.4. Thread the stem nut (12) onto the stem. Tighten the stem nut to the torque figures (**table 1**).
- 10.5. Place the locking clip (13) on the stem nut by adjusting the orientation of the nut (in the clockwise direction).
- 10.6. Place the handle, serrated washer and thread the handle nut on the stem (14, 15, 16). Holding the handle tighten the handle nut tight.
- 10.7. Bring the handle to the closed position to insert the ball (14).
- 10.8. Place the ball in the center body until the stem tongue is engaged and bring the valve to the open position to prevent the ball from falling out.
- 10.9. Place the new hybrid seats (5,5A) and new body and seat seals (6, 5B, 5C (optional)) in the body.

- 10.10. Ease back the body assembly between end connectors, taking care not to score faces or damage seals, and reinstall body bolts and nuts.
 - 10.11. To prevent galling of threads of bolts or nuts, lubricate threads with an anti-galling compound.
 - 10.12. Tighten the body bolts to the torque figures (**table 2**), and according to tightening pattern illustrated in **figure 4**.
- Leave the valve in the open position for flushing the line.

11. Large valves assembly

The following instructions are for in-line assembly of valves sizes 1 ½" to 8".

- 11.1. Lubricate the new stem thrust seal, bearing (10A) and packing (9), with appropriate lubricant (Molykote 33 - thin smear). Place the stem thrust seal (7) on the stem (4).
- 11.2. Insert the stem horizontally into the center body (1) with the threaded side first and carefully guide it up through the stem bore.
- 11.3. Holding the stem up insert the new packing (9) over the stem and into the stem bore. Place the stem trust seal (7A), slide bearing (10A) (only in fire safe valve), follower (10), stop plate (14A) and the locking clip (13) onto the stem
- 11.4. Thread the slotted gland nut (12) onto the stem. Tighten the gland nut to the torque figures (**table 1**) and lock the locking clip on the nut.
- 11.5. Place the wrench head (14B) on the stem making sure it is parallel to the stem groove for ball valve position. Insert the handle (14) through the wrench head and tighten with the wrench bolt (16).
- 11.6. Bring the handle to the closed position to insert the ball.
- 11.7. Place the ball in the center body until the stem tongue is engaged and bring the valve to the open position to prevent the ball from falling out.
- 11.8. Place the new body seat rings, seat retaining ring and new body seals in the body.
- 11.9. Ease back the body assembly between end connectors, taking care not to score faces or damage seals, and reinstall body bolts and nuts.
- 11.10. To prevent galling of threads of bolts or nuts, lubricate threads with an anti-galling compound.
- 11.11. Tighten the body bolts to the torque figures (**table 2 or 3**), and according to tightening sequence illustrated in **figure 8**.
- 11.12. Leave the valve in the open position for flushing the line.

1/4" TO 1"

FIGURE 1

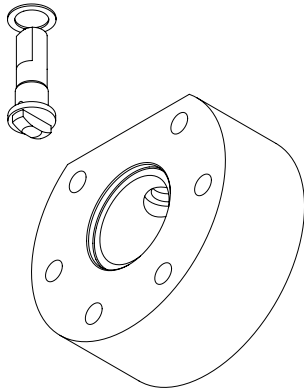

FIGURE 2

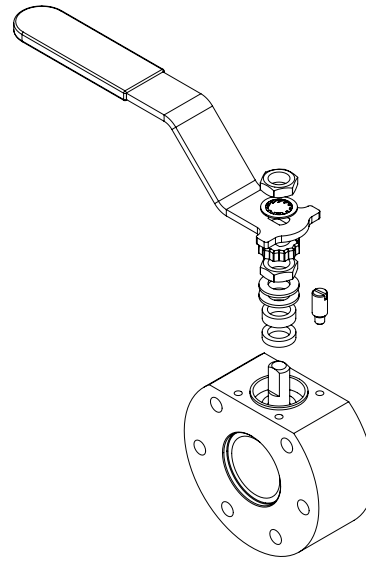

FIGURE 3

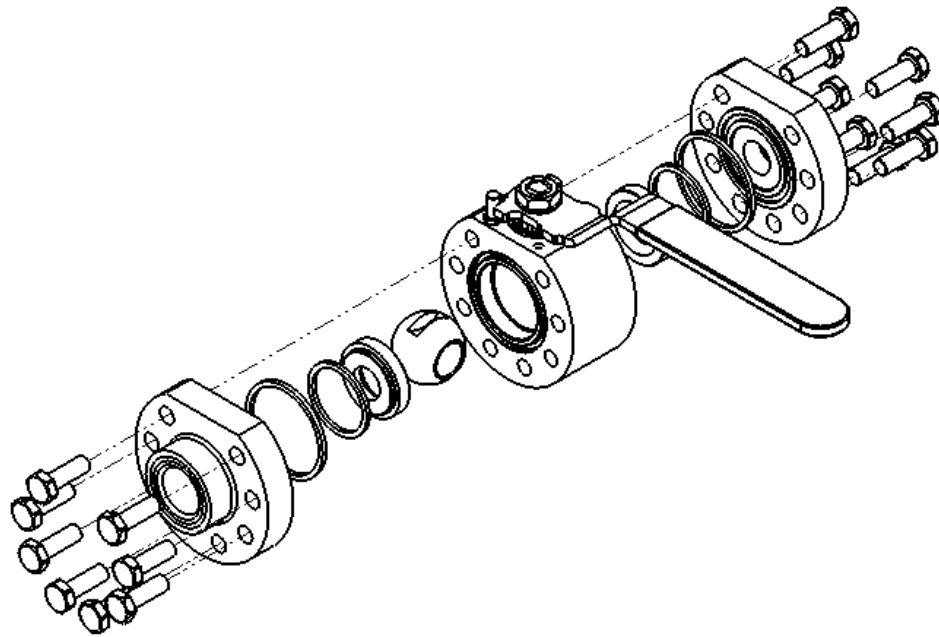
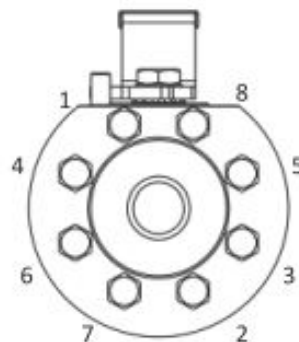

FIGURE 4
Body Bolt Tightening Pattern



1 1/2" TO 8"

FIGURE 5

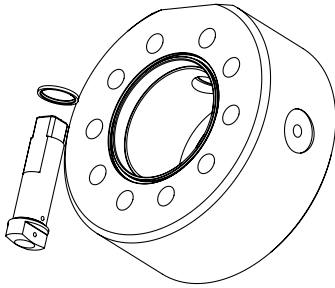

FIGURE 6

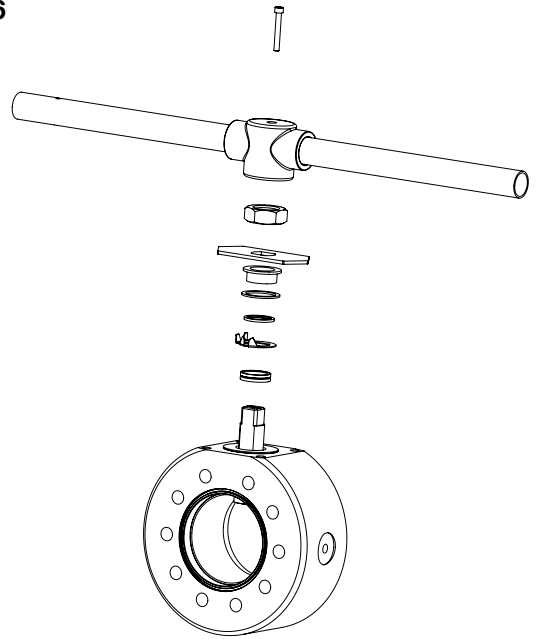

FIGURE 7

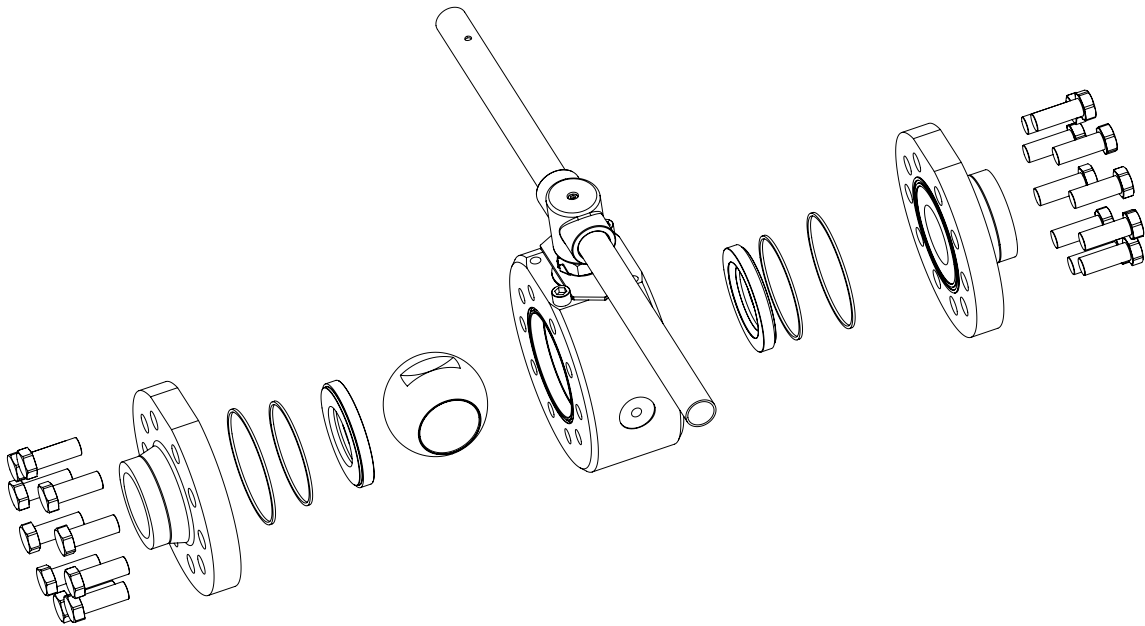

FIGURE 8
Body Bolt Tightening Pattern

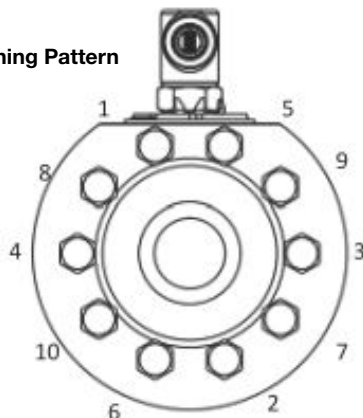

FIGURE 7

Valve Marking and Labeling

All valves marking is on a nameplate which is spot welded to the valve body. Valves for the European market and above 1" carry the CE mark with the information required by the PED.

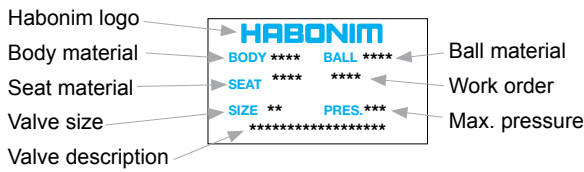

TABLE 1

Stem Nut Tightening Torque

Valve Size		Stem Size	Stem Thread Size	Torque					
				CF PTFE		HERMETIX		GRAPHITE	
Reduced Bore	Full Bore			Nm	Lb-In	Nm	Lb-In	Nm	Lb-In
1/2"	1/4", 3/8"	0.5"	3/8" - 24 UNF-2A	4	35	6	53	6	53
3/4"	1/2"	1"	7/16" - 20 UNF-2A	9	80	11	97	11	97
1"	3/4"	1.5"	9/16" - 18 UNF-2A	13	115	15	133	16	140
1-1/4"	1"	1.5"	9/16" - 18 UNF-2A	13	115	15	133	16	140
1-1/2"	1-1/4"	2.5"	M20x2.5-6G	30	265	30	265	30	265
2"	1-1/2"	2.5"	M20x2.5-6G	30	265	30	265	30	265
2-1/2"	2"	3"	1-1/4" UNS-2A	60	530	60	530	60	530
3"	2-1/2"	6"	1-1/2" - 12 UNF-2A	120	1060	120	1060	120	1060
4"	3"	6"	1-1/2" - 12 UNF-2A	120	1060	120	1060	120	1060
6"	4"	10"	2" - 8 UN-2A	250	2213	300	2655	300	2655
8"	6"	12"	2"-3/4" - 8 UN-2A	335	2965	400	3540	400	3540

TABLE 2

Body Bolt Tightening Torque

Valve Size	Thread Size	Tightening Torque			
		8.8 Bolts		A4-80 Bolts	
		Nm	Lb-In	Nm	Lb-In
1/4", 3/8"	M8	25	221	30	265
1/2"	M8	25	221	30	265
3/4"	M8	25	221	30	265
1"	M10	48	425	65	575
1-1/4"	M12	83	735	100	885
1-1/2"	M12	83	735	100	885
2"	M16	200	1770	245	2168
2-1/2"	M16	200	1770	245	2168
3"	M20	390	3452	490	4337
4"	M20	390	3452	490	4337
6"	M24	560	4900	600	5310
8"	M30	1100	9740	900	7965

1/4" TO 1 1/2"

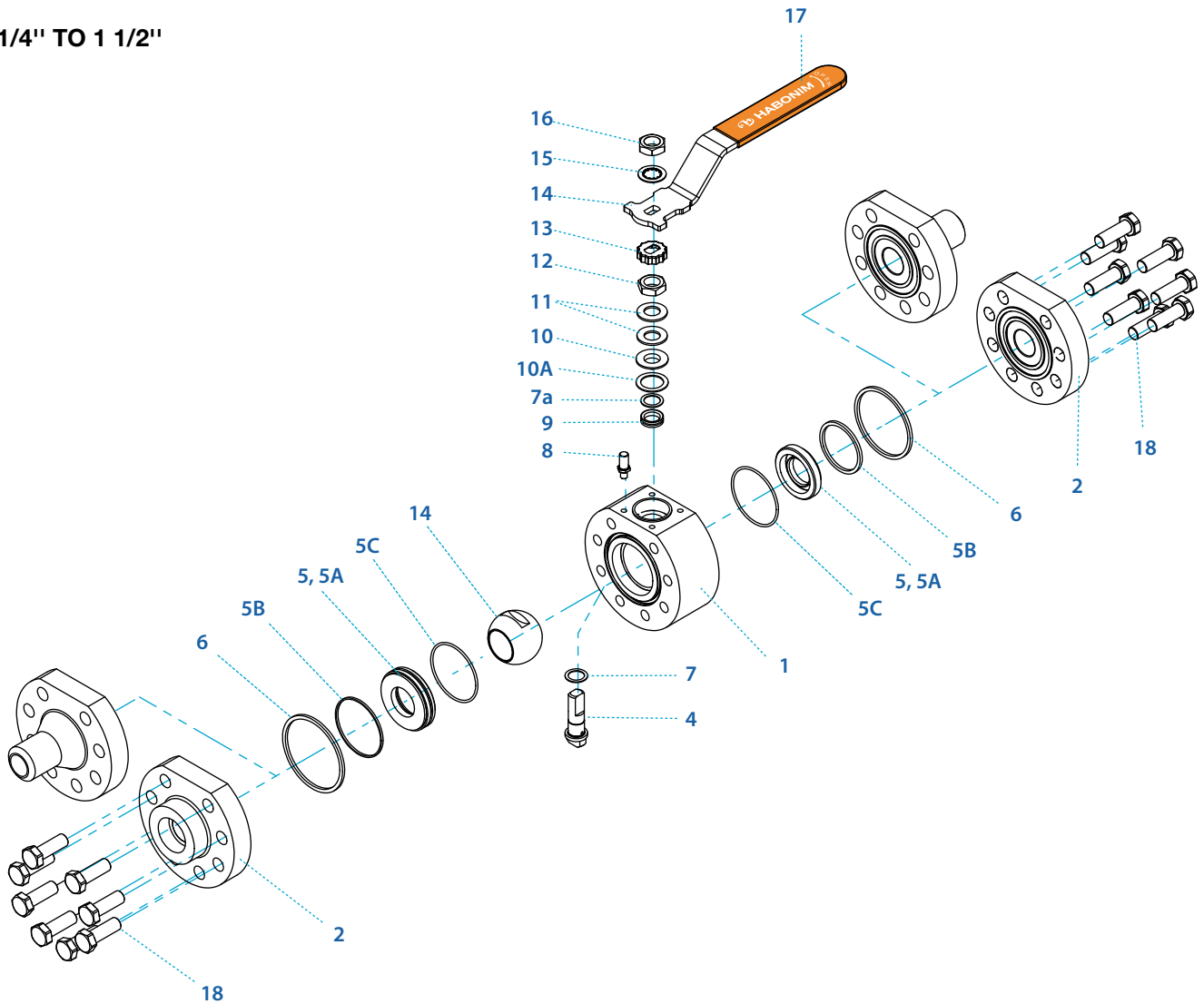

Item	Description	Material specification	Qty.
1	Body	S.St. A479 316/316L, C.St. A350 LF2, B473 N08020 (Alloy 20), B164 N04400 (Monel 400), B574 N06022 (Alloy C22), B574 N10276 (Alloy C276), A479 S31254 (254 SMO), A479 S31803 (Duplex), A479 S32750 (Super Duplex)	1
2	End	A479 316/316L, A350 LF2, B473 N08020, B164 N04400, B574 N06022, B574 N10276, A479 S31254, A479 S31803, A479 S32750	2
3	Ball	A564 Gr.630 H1150D 17-4PH, S.St. A351 CF8M, A479 316/316L, B473 N08020, B164 N04400, B574 N06022, B574 N10276, A479 S31254, A479 S31803, A479 S32750, B637 UNS-N07718 (Inconel 718)	1
4	Stem	A564 Gr.630 H1150D 17-4PH, B164 N04400, B574 N06022, A479 S31803, A479 S32750, B637 UNS-N07718 (Inconel 718)	1
5*	Seat insert	PVDF, DELRIN, PEEK, CF PEEK, PCTFE (KEL-F)	2
5A*	Seat housing	A479 316/316L, A350 LF2, B473 N08020, B164 N04400, B574 N06022, B574 N10276, A479 S31254, A479 S31803, A479 S32750	2
5B*	Seat seal	PTFE, Graphite, NBR, Viton	2
5C*	Seat seal (optional)	NBR, Viton	2
6*	Body seal	PTFE, Graphite, NBR, Viton	2
7*	Stem thrust seal	PEEK, CF PEEK, PCTFE (KEL-F), TFM ⁽²⁾ , CF PTFE ⁽²⁾	1

Item	Description	Material specification	Qty.
7a**	Anti-abrasion ring	PEEK, CF PEEK, PCTFE (KEL-F), TFM ⁽²⁾ , CF PTFE ⁽²⁾	1
8	Stop pin	A582 303	1
9*	Stem seal	CF PTFE, TFM, Graphite ⁽²⁾	1
10	Follower	B783 316L	1
10A*	Slide bearing	TF316	1
11	Disc spring	A693 631 17-7PH	2
12	Stem nut	A194 8M, EN3506-2 A4-80	1
13	Locking clip	A240 304	1
14	Handle	C.St. A29 G10200 Zinc plate, S.St. A240 430	1
15	Serrated washer	A194 6	1
16	Handle nut	A194 8M, EN3506-2 A4-80	1
17	Sleeve	PVC	1
18	Body bolts	A193 B8M, EN3506-1 A4-80	12-16
20	Anti static spring	A313 302	1
21	Anti static plunger	A479 304	1
23	Tag (not shown)	A167 304	1

* Repair kit components

** Only with HermetiX™ stem seal. Does not supplied in 1/2" and 3/4" valves

⁽¹⁾ 28 Series is Habonim's standard valve design without the HermetiX™ stem seal construction

⁽²⁾ This material can only be used as part of non HermetiX™ design

1 1/2" TO 6"

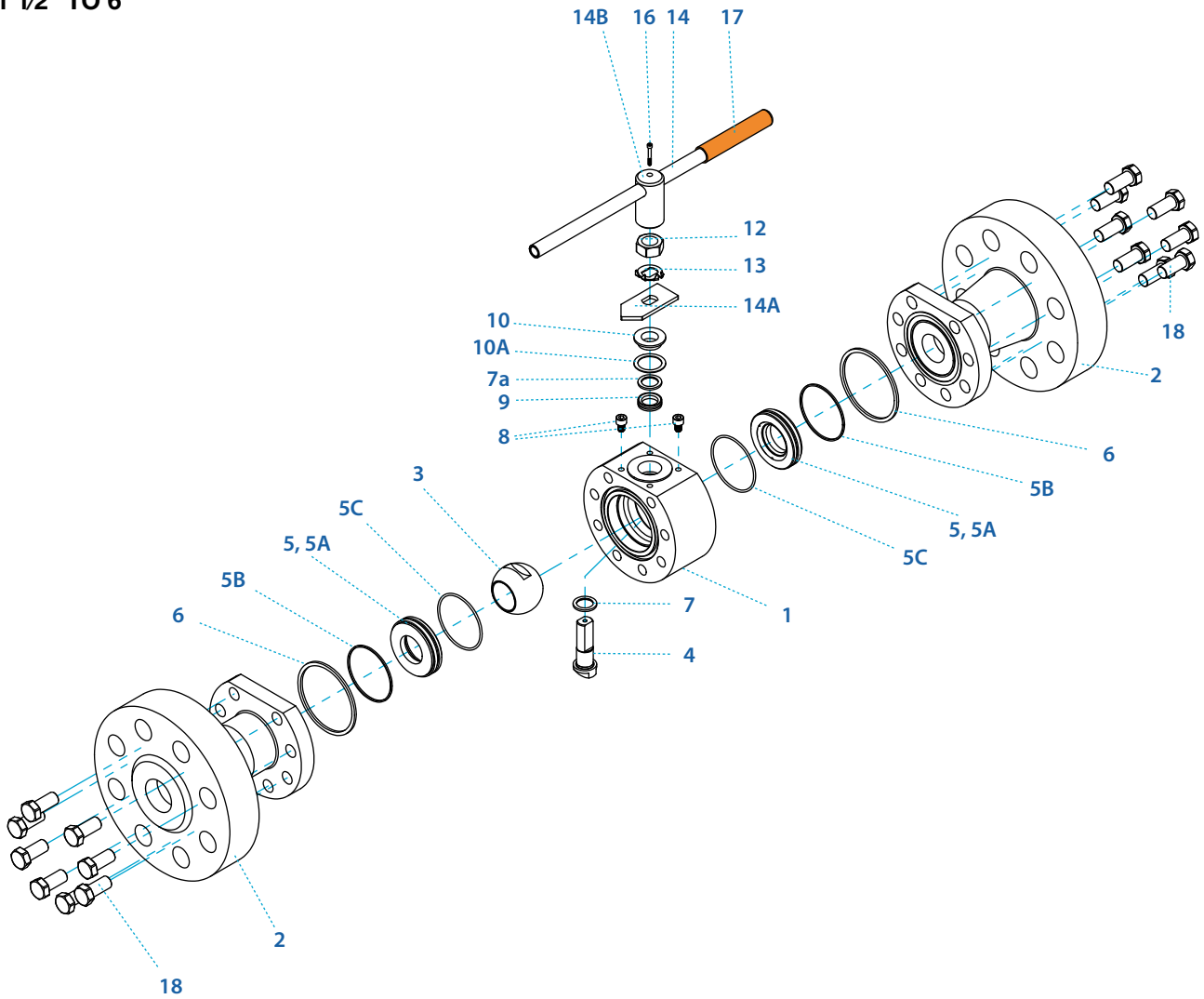

Item	Description	Material specification	Qty.
1	Body	S.St. A479 316/316L, C.St. A350 LF2, B473 N08020 (Alloy 20), B164 N04400 (Monel 400), B574 N06022 (Alloy C22), B574 N10276 (Alloy C276), A479 S31254 (254 SMO), A479 S31803 (Duplex), A479 S32750 (Super Duplex)	1
2	End	A479 316/316L, A350 LF2, B473 N08020, B164 N04400, B574 N06022, B574 N10276, A479 S31254, A479 S31803, A479 S32750	2
3	Ball	S.St. for 1/2" and 3/4" valves: A564 Gr.630 H1150D 17-4PH, S.St. for 1" and up valves: A351 CF8M, A479 316/316L, B473 N08020, B164 N04400, B574 N06022, B574 N10276, A479 S31254, A479 S31803, A479 S32750, B637 UNS-N07718 (Inconel 718)	1
4	Stem	A564 Gr.630 H1150D 17-4PH, B164 N04400, B574 N06022, A479 S31803, A479 S32750, B637 UNS-N07718 (Inconel 718)	1
5*	Seat insert	PVDF, DELRIN, PEEK, CF PEEK, PCTFE (KEL-F)	2
5A*	Seat housing	A479 316/316L, A350 LF2, B473 N08020, B164 N04400, B574 N06022, B574 N10276, A479 S31254, A479 S31803, A479 S32750	2
5B*	Seat seal	PTFE, Graphite, NBR, Viton	2
5C*	Seat seal (optional)	NBR, Viton	2
6*	Body seal	PTFE, Graphite, NBR, Viton	2
7*	Stem thrust seal	PEEK, CF PEEK, PCTFE (KEL-F), TFM ⁽²⁾ , CF PTFE ⁽²⁾	1

Item	Description	Material specification	Qty.
7a**	Anti-abrasion ring	PEEK, CF PEEK, PCTFE (KEL-F), TFM ⁽²⁾ , CF PTFE ⁽²⁾	1
8	Stop pin	A582 303	1
9*	Stem seal	CF PTFE, TFM, Graphite ⁽²⁾	1
10	Follower	B783 316L	1
10A*	Slide bearing	TF316	1
12	Stem nut	A194 8M, EN3506-2 A4-80	1
13	Tab lock washer	A240 304	1
14	Handle	C.St. Zinc plate, A240 316L	1
14A	Stop plate	C.St. 1.0402 Zinc plate, A240 430	1
14B	Wrench head	Ductile Iron A536 Gr. 65-45-12, A216 WCB, A351 CF8M	1
16	Wrench bolt	EN3506-1 A2-70/A4-80, A193 Gr B8/B8M	1
17	Sleeve	PVC	1
18	Body bolts	A193 B8M, EN3506-1 A4-80	16-30
20	Anti static spring	A313 302	2
21	Anti static plunger	A479 304	2
23	Tag (not shown)	A167 304	1

* Repair kit components

** Only with HermetiX™ stem seal

⁽¹⁾ 28 Series is Habonim's standard valve design without the HermetiX™ stem seal construction

⁽²⁾ This material can only be used as part of non HermetiX™ design